

深圳市占開科技有限公司

ShenZhen ZhanKai Technology CO.,LTD

TEL:0769-81802125 FAX:0769-81802126

DOCUMENT NO.

RDE0105A

SERIAL NO.

B2011H0*-NP

Material:Nylon 66 UL 94V-0

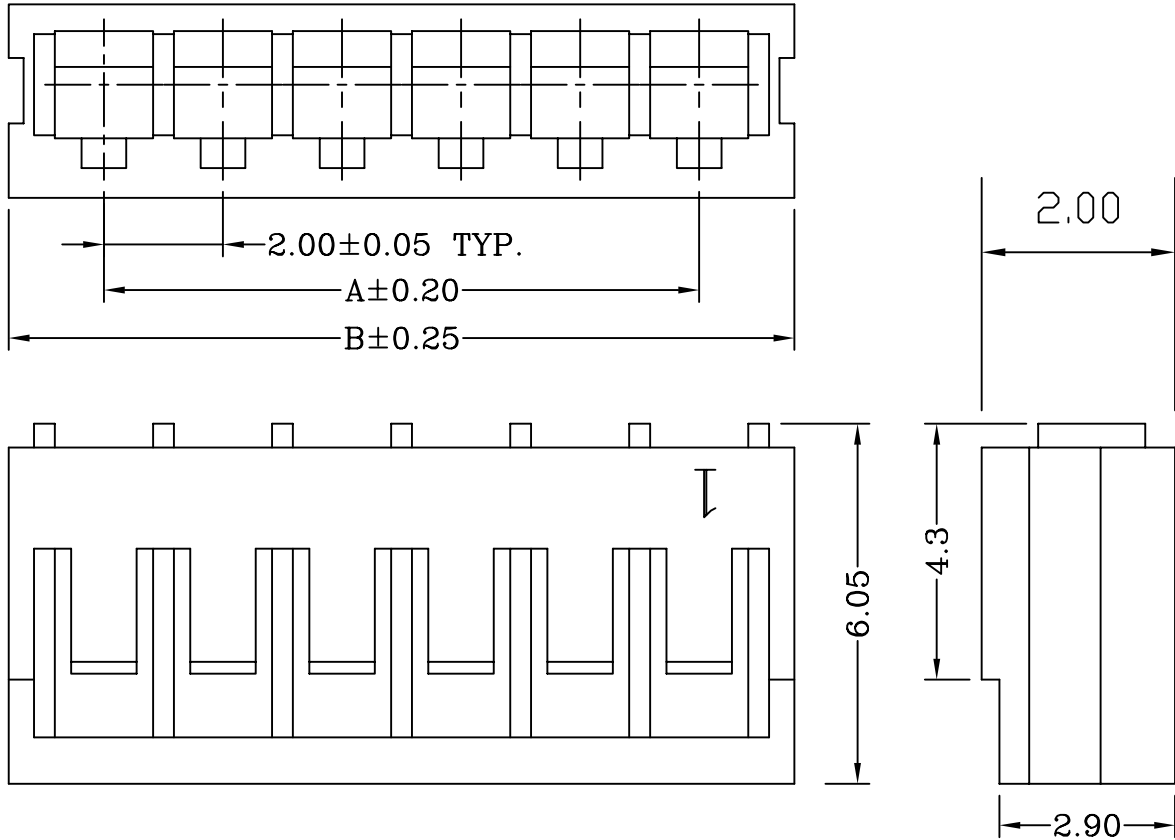

Dimensional & Ordering Information:

Circuits	Part No	Dimension mm	
		A	B
2	B2011H00-2P	2.00	5.20
3	B2011H00-3P	4.00	7.20
4	B2011H00-4P	6.00	9.20
5	B2011H00-5P	8.00	11.20
6	B2011H00-6P	10.00	13.20
7	B2011H00-7P	12.00	15.20
8	B2011H00-8P	14.00	17.20
9	B2011H00-9P	16.00	19.20
10	B2011H00-10P	18.00	21.20
11	B2011H00-11P	20.00	23.20
12	B2011H00-12P	22.00	25.20
13	B2011H00-13P	24.00	27.20
14	B2011H00-14P	26.00	29.20
15	B2011H00-15P	28.00	31.20
16	B2011H00-16P	30.00	33.20

REV.	ECN NO.	UNIT	TOLERANCE	PROJECTION	DRAWING	CHECK	APPROVAL
△	NEW DRAWING	mm	*** ±0.08		邹朝辉	—————	余望明
△			** ±0.15				
			* ±0.25				

深圳市占開科技有限公司

ShenZhen ZhanKai Technology CO.,LTD

TEL:0769-81802125

FAX:0769-81802126

DOCUMENT NO.

RDE0097A

SERIAL NO.

B2011T0B-2e

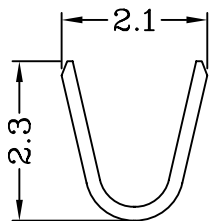
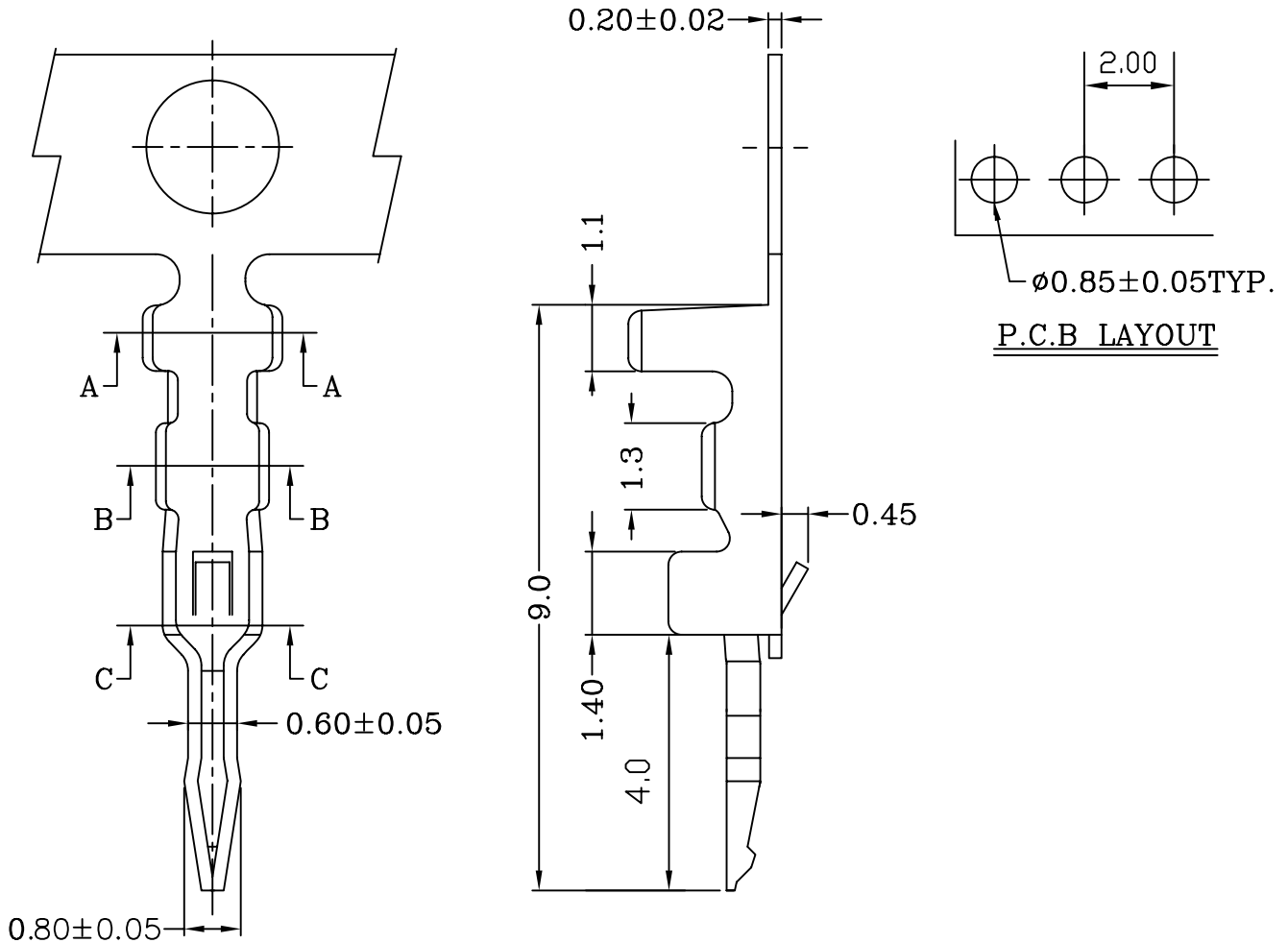

Section A-A

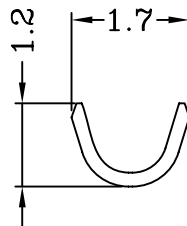

Section B-B

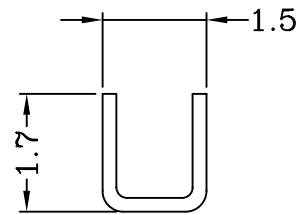

Section C-C

Specifications & Ordering Information:

Part No	Wire Range	Insulation O.D.	Material	Finish	Qty/reel	NOTE
B2011T0B-2e	AWG #24~#30	1.40mm(max)	bronze	Tin-plated	8,000 PCS	e:Stamping before tin plated

REV.	ECN NO.	UNIT	TOLERANCE	PROJECTION	DRAWING	CHECK	APPROVAL
	NEW DRAWING	mm	*** ± 0.08 ** ± 0.15 * ± 0.25		王昊	——	余望明