

# 深圳市占開科技有限公司

ShenZhen ZhanKai Technology CO.,LTD

TEL:0769-81802125 FAX:0768-81802126

DOCUMENT NO.

RDE0042A

SERIAL NO.

B1501H00-NP

Material:Nylon 66 UL 94V-0

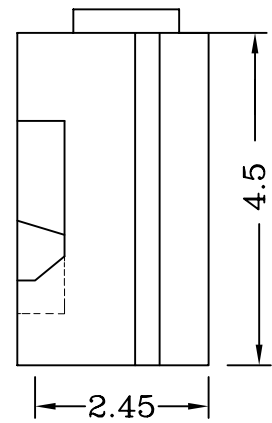
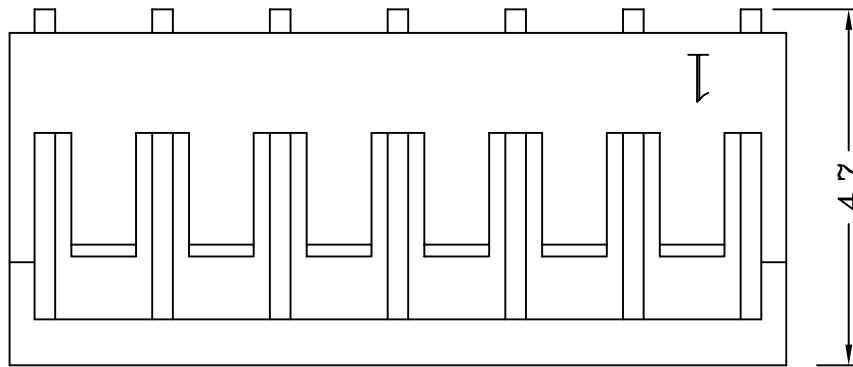
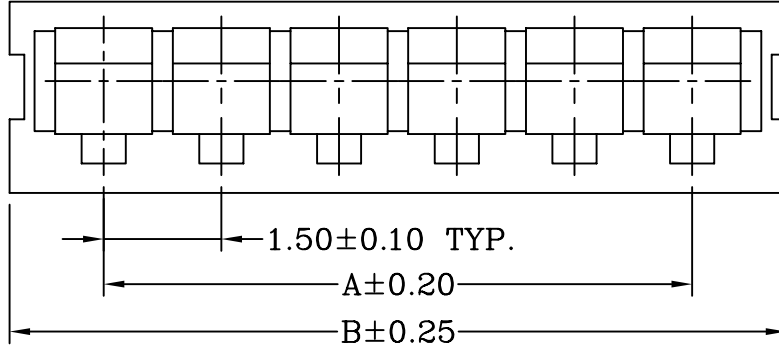

### Dimensional & Ordering Information:

Circuits	Part No	Dimension mm	
		A	B
2	B1501H00-2P	1.50	3.60
3	B1501H00-3P	3.00	5.10
4	B1501H00-4P	4.50	6.60
5	B1501H00-5P	6.00	8.10
6	B1501H00-6P	7.50	9.60
7	B1501H00-7P	9.00	11.10
8	B1501H00-8P	10.50	12.60
9	B1501H00-9P	12.00	14.10
10	B1501H00-10P	13.50	15.60
11	B1501H00-11P	15.00	17.10
12	B1501H00-12P	16.50	18.60
13	B1501H00-13P	18.00	20.10
14	B1501H00-14P	19.50	21.60
15	B1501H00-15P	21.00	23.10
16	B1501H00-16P	22.50	24.60

REV.	ECN NO.	UNIT	TOLERANCE	PROJECTION	DRAWING	CHECK	APPROVAL
A	NEW DRAWING	mm	*** ±0.08		邹朝辉	———	余望明
B			** ±0.15				
			* ±0.25				

# 深圳市占開科技有限公司

ShenZhen ZhanKai Technology CO.,LTD

TEL:0769-81802125

FAX:0768-81802126

DOCUMENT NO.

RDE0135A

SERIAL NO.

B1501T0\*-2(e)

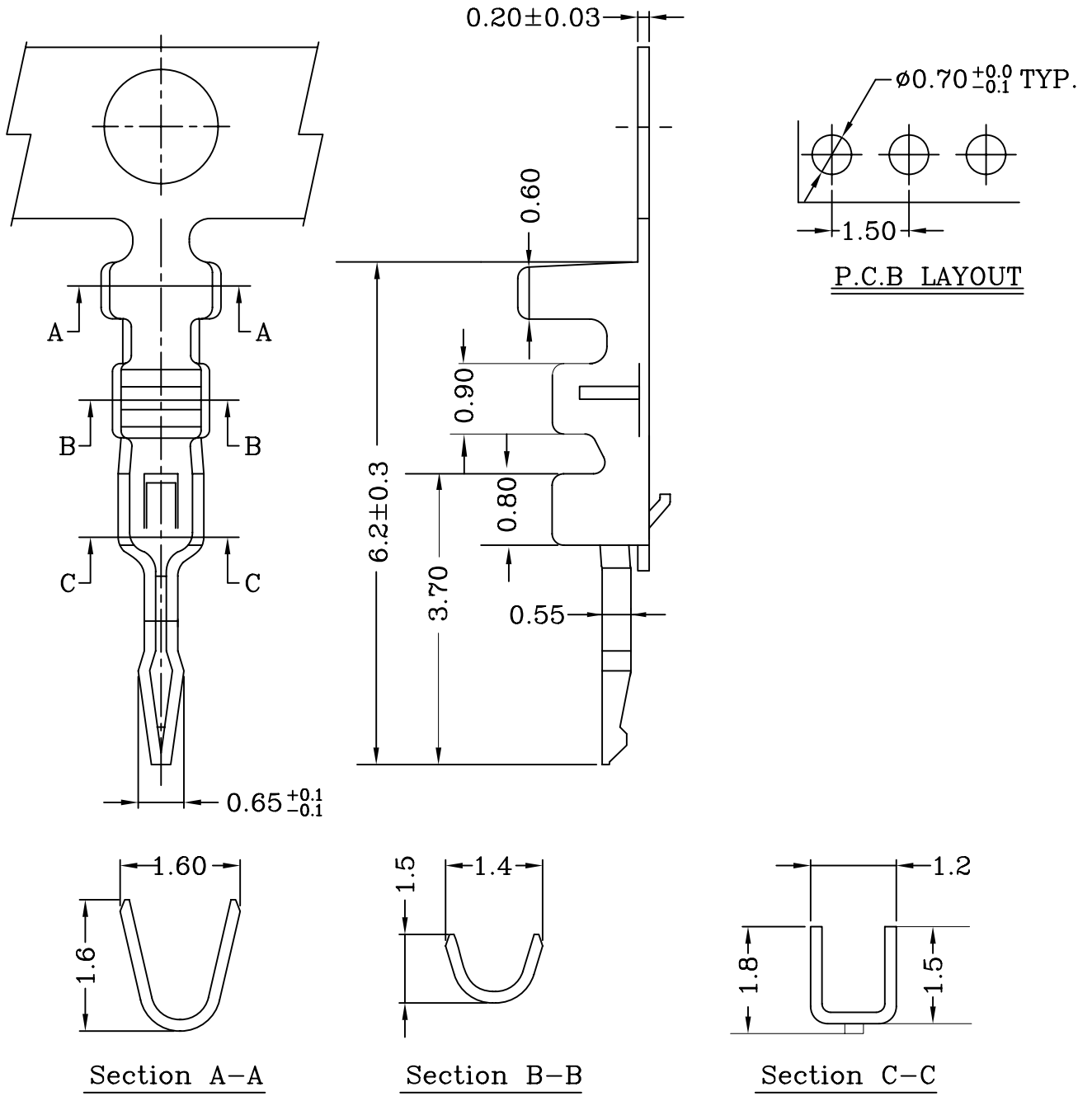

Specifications & Ordering Information:

Part No	Wire Range	Insulation O.D.	Material	Finish	Qty/reel	NOTE
B1501TOP-2	AWG #26~#30	1.00mm(max)	Phosphor bronze	Tin-plated	10,000 PCS	e:Stamping before tin plated
B1501TOB-2e	AWG #26~#30	1.00mm(max)	Brass	Tin-plated	10,000 PCS	

REV.	ECN NO.	UNIT	TOLERANCE	PROJECTION	DRAWING	CHECK	APPROVAL
	NEW DRAWING	mm	*** ±0.08 ** ±0.15 * ±0.25		邹朝辉	———	余望明