

深圳市占開科技有限公司

ShenZhen ZhanKai Technology CO.,LTD

TEL:0769-81802125 FAX:0769-81802126

DOCUMENT NO.

RDE0031A

SERIAL NO.

A1501H00-NP

Material: Nylon 66 UL 94V-0

Specifications:

| | |
|-----------------------|----------------|
| Poles | 2-15 Poles |
| Pitch between poles | 1.5mm |
| Rated Voltage | 100V AC,DC |
| Rated Current | 1A(AWG #28) |
| Withstand Voltage | 500V AC/minute |
| Contact Resistance | 20mΩ (MAX) |
| Insulation Resistance | 500mΩ (MIN) |
| Temperature Range | -25°C ~ +85°C* |
| Applicable Wire Range | AWG #26 ~ #32 |

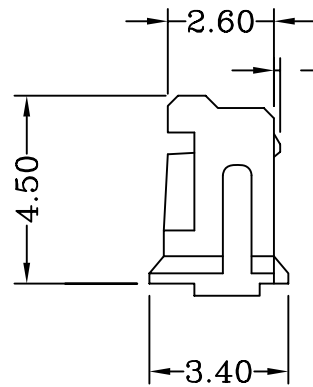
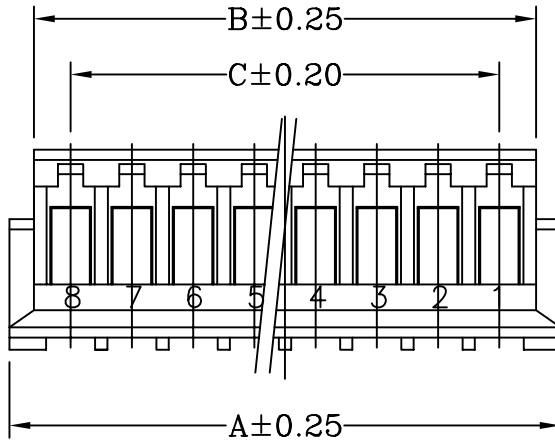
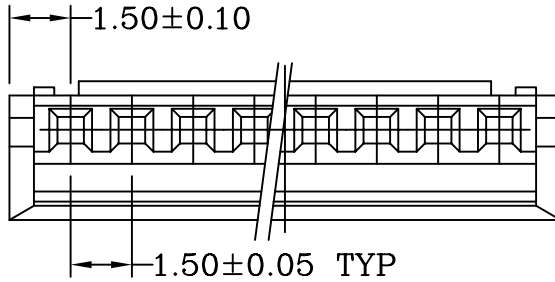

Dimensional & Ordering Information:

| Circuits | Part No | Dimensions | | | Pcs/Bag |
|----------|--------------|------------|-------|-------|---------|
| | | A | B | C | |
| 2 | A1501H00-2P | 4.50 | 3.45 | 1.50 | 1000 |
| 3 | A1501H00-3P | 6.00 | 4.95 | 3.00 | 1000 |
| 4 | A1501H00-4P | 7.50 | 6.45 | 4.50 | 1000 |
| 5 | A1501H00-5P | 9.00 | 7.95 | 6.00 | 1000 |
| 6 | A1501H00-6P | 10.50 | 9.45 | 7.50 | 1000 |
| 7 | A1501H00-7P | 12.00 | 10.95 | 9.00 | 1000 |
| 8 | A1501H00-8P | 13.50 | 12.45 | 10.50 | 1000 |
| 9 | A1501H00-9P | 15.00 | 13.95 | 12.00 | 1000 |
| 10 | A1501H00-10P | 16.50 | 15.45 | 13.50 | 1000 |
| 11 | A1501H00-11P | 18.00 | 16.95 | 15.00 | 1000 |
| 12 | A1501H00-12P | 19.50 | 18.45 | 16.50 | 1000 |
| 13 | A1501H00-13P | 21.00 | 19.95 | 18.00 | 1000 |
| 14 | A1501H00-14P | 22.50 | 21.45 | 19.50 | 1000 |

| REV. | ECN NO. | UNIT | TOLERANCE | PROJECTION | DRAWING | CHECK | APPROVAL |
|------|---------|------|----------------------------------|------------|---------|-------|----------|
| | | mm | *** ±0.08 ** ±0.15 * ±0.25 | | 王 昊 | —— | 胡伟荣 |

深圳市占開科技有限公司

ShenZhen ZhanKai Technology CO.,LTD

TEL:0769-81802125 FAX:0769-81802126

DOCUMENT NO.

RDE0033B

SERIAL NO.

A1501T0*-2

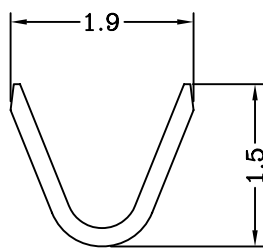
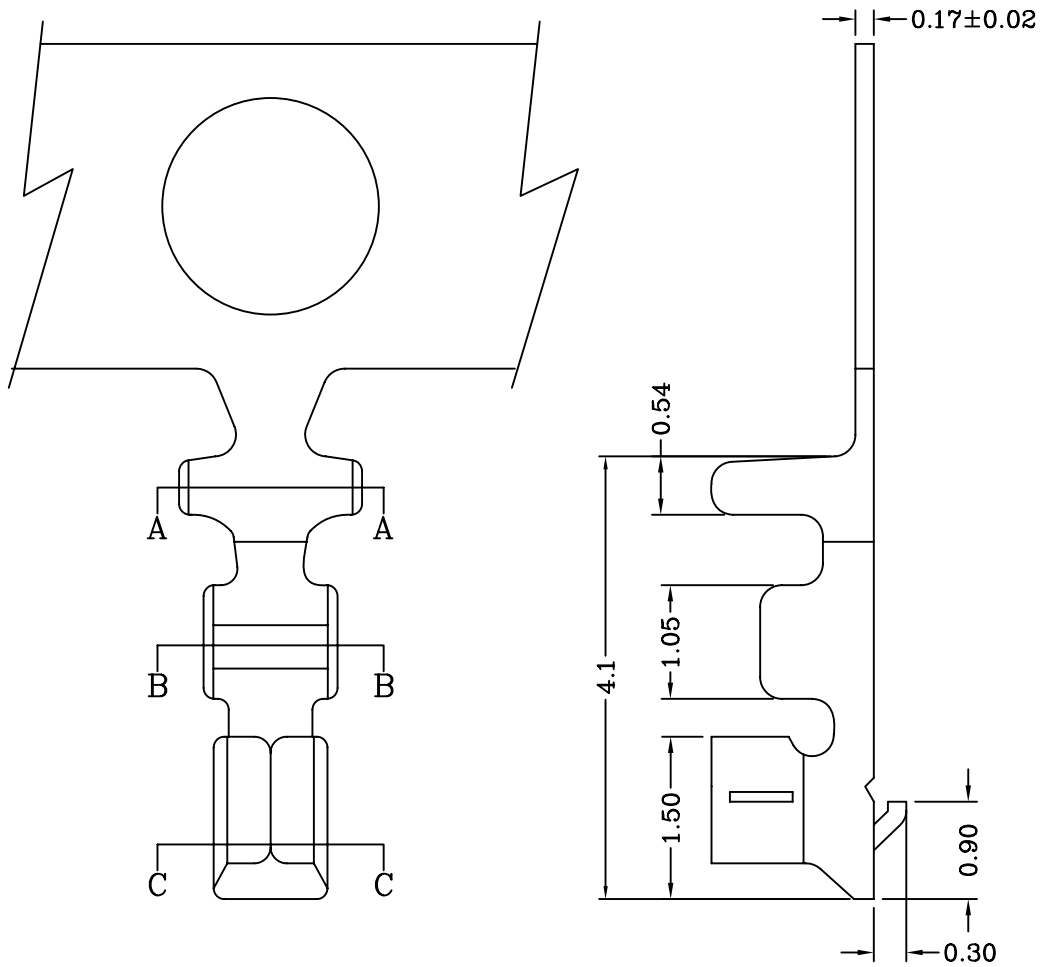

Section A-A

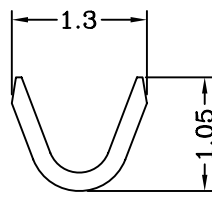

Section B-B

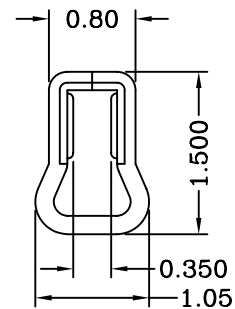

Section C-C

| Part No. | Wire Range | Insulation O.D. | Material | Finish | Q'ty / reel |
|------------|------------|-----------------|-----------------|------------|-------------|
| A1501TOP-2 | AWG# 26~30 | 0.90mm (MAX) | Phosphor Bronze | Tin Plated | 15,000 pcs |

| REV. | ECN NO. | UNIT | TOLERANCE | PROJECTION | DRAWING | CHECK | APPROVAL |
|------|---------|------|----------------------------------|------------|---------|-------|----------|
| | | mm | *** ±0.08 ** ±0.15 * ±0.25 | | 王昊 | —— | 胡伟荣 |