

深圳市占開科技有限公司

ShenZhen ZhanKai Technology CO.,LTD

TEL:0769-81802125

FAX:0769-81802126

DOCUMENT NO.

RDE0108A

SERIAL NO.

A1256H00-1xNP

Material: Nylon 66 UL 94V-0

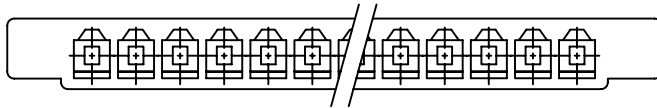
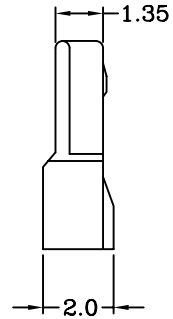
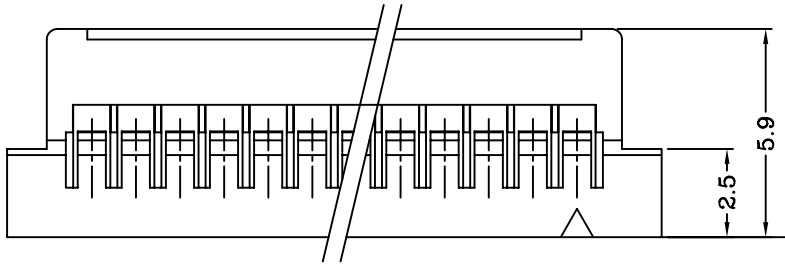
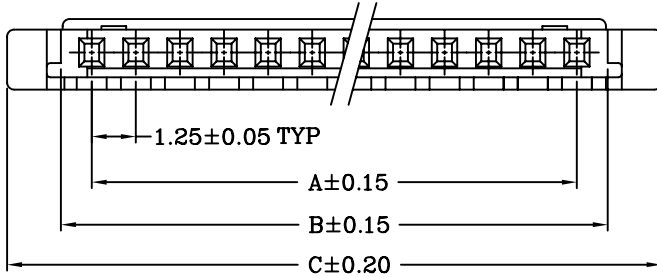

7P~20P

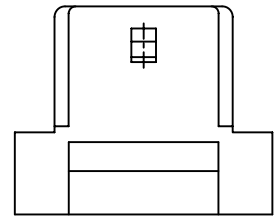
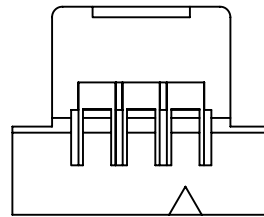
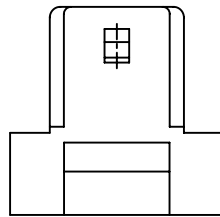
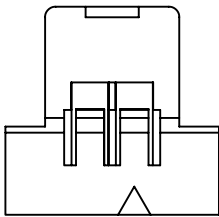

2P

3P

2P~6P為一個凸點

Dimensional & Ordering Information:

Circuits	Part No.	Dimensions			Pcs/Bag	Circuits	Part No.	Dimensions			Pcs/Bag
		A	B	C				A	B	C	
2	A1256H00-1x2P	1.25	3.00	6.05	1000	9	A1256H00-1x9P	10.00	11.75	14.80	1000
3	A1256H00-1x3P	2.50	4.25	7.30	1000	10	A1256H00-1x10P	11.25	13.00	16.05	1000
4	A1256H00-1x4P	3.75	5.50	8.55	1000	15	A1256H00-1x15P	17.50	19.25	22.30	1000
5	A1256H00-1x5P	5.00	6.75	9.80	1000	20	A1256H00-1x20P	23.75	25.50	28.55	1000
6	A1256H00-1x6P	6.25	8.00	11.05	1000						
7	A1256H00-1x7P	7.50	9.25	12.30	1000						
8	A1256H00-1x8P	8.75	10.50	13.55	1000						

REV.	ECN NO.	UNIT	TOLERANCE	PROJECTION	DRAWING	CHECK	APPROVAL
A	NEW DRAWING	mm	*** ±0.08		涂红军	—	邹朝辉
B			** ±0.15				
			* ±0.25				

深圳市占開科技有限公司

ShenZhen ZhanKai Technology CO.,LTD

TEL:0769-81802125

FAX:0769-81802126

DOCUMENT NO.

RDE0109A

SERIAL NO.

A1256TOP-0*+

A--Gold Plated Area.

B--Tested Area For Coating Thickness.

C--Point of Measurement For Coating Thickness

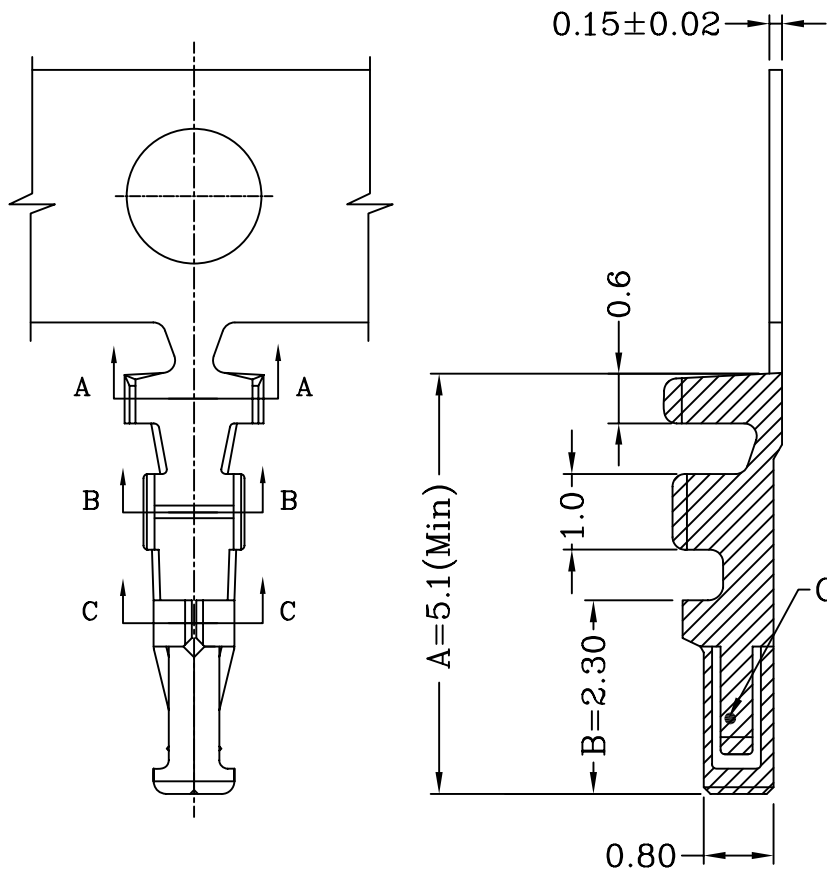

0*+--Au Flash

00+-- 1μ "

0A+-- 3μ "

0B+-- 4μ "

0C+-- 5μ "

0D+-- 15μ "

0E+-- 30μ "

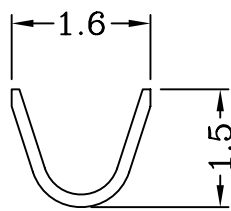

SECTION A-A

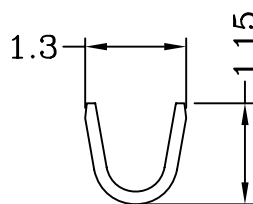

SECTION B-B

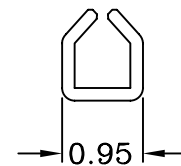

SECTION C-C

Specification & Ordering Information:

Part No	Wire Range	Insulation O.D.	Material	Finish	Qty/reel
A1256TOP-0*+	AWG #28~#32	0.90mm(max)	Phosphor bronze	Gold over Nickel	20,000 pcs

REV.	ECN NO.	UNIT	TOLERANCE	PROJECTION	DRAWING	CHECK	APPROVAL
<u>A</u>	NEW DRAWING	mm	*** ± 0.08		涂红军	—	邹朝辉
<u>B</u>			** ± 0.15				
			* ± 0.25				