

深圳市占開科技有限公司

ShenZhen ZhanKai Technology CO.,LTD

TEL:0769-81802125

FAX:0769-81802126

DOCUMENT NO.

RDE0110A

SERIAL NO.

A1254H00-NP

Material: Nylon 66 UL 94V-0

① Circuit No. 1

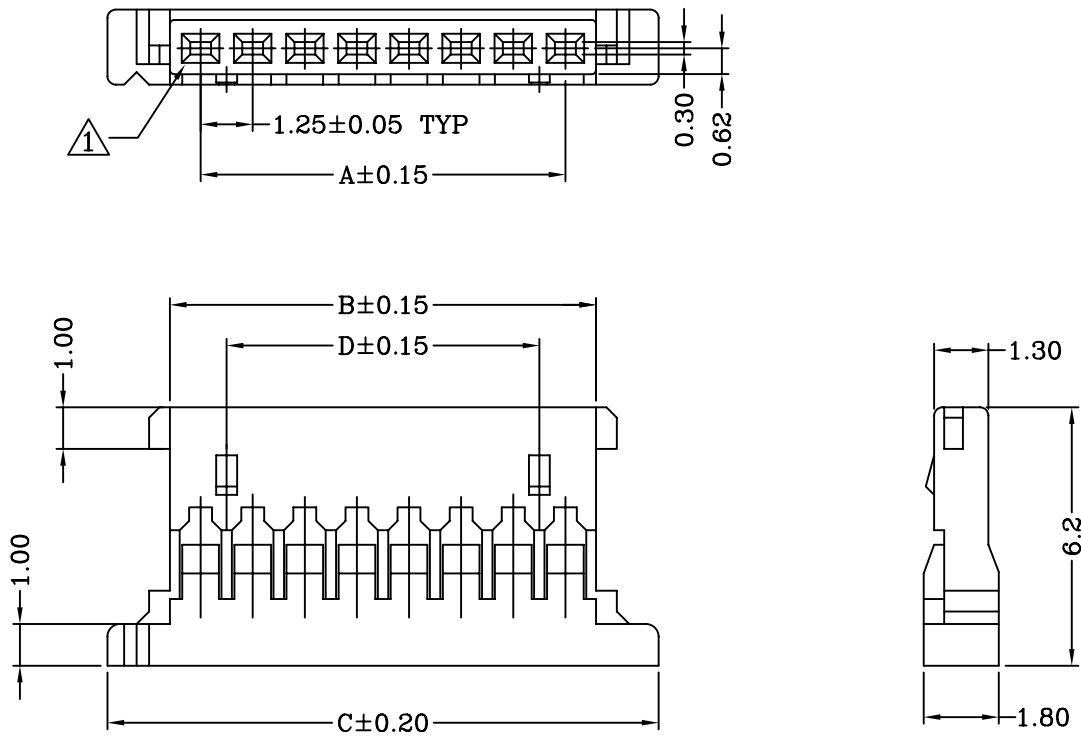

Dimensional & Ordering Information:

Circuits	Part No.	Dimensions				Pcs/Bag
		A	B	C	D	
2	A1254H00-2P	1.25	2.72	5.72	—	1000
3	A1254H00-3P	2.50	3.97	6.97	—	1000
4	A1254H00-4P	3.75	5.22	8.22	2.50	1000
5	A1254H00-5P	5.00	6.47	9.47	3.75	1000
6	A1254H00-6P	6.25	7.72	10.72	5.00	1000
7	A1254H00-7P	7.50	8.97	11.97	6.25	1000
8	A1254H00-8P	8.75	10.22	13.22	7.50	1000
9	A1254H00-9P	10.00	11.47	14.47	8.75	1000

REV.	ECN NO.	UNIT	TOLERANCE	PROJECTION	DRAWING	CHECK	APPROVAL
△A	NEW DRAWING	mm	.*** ±0.08		王昊	——	余望明
△B			.** ±0.15				
			.* ±0.25				

深圳市占開科技有限公司

ShenZhen ZhanKai Technology CO.,LTD

TEL:0769-81802125

FAX:0769-81802126

DOCUMENT NO.

RDE0030A

SERIAL NO.

A1254TOP-0*

A--Gold Plated Area.

B--Tested Area For Coating Thickness.

C--Point of Measurement For Coating Thickness

0*--Au Flash

00--1μ”

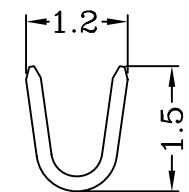
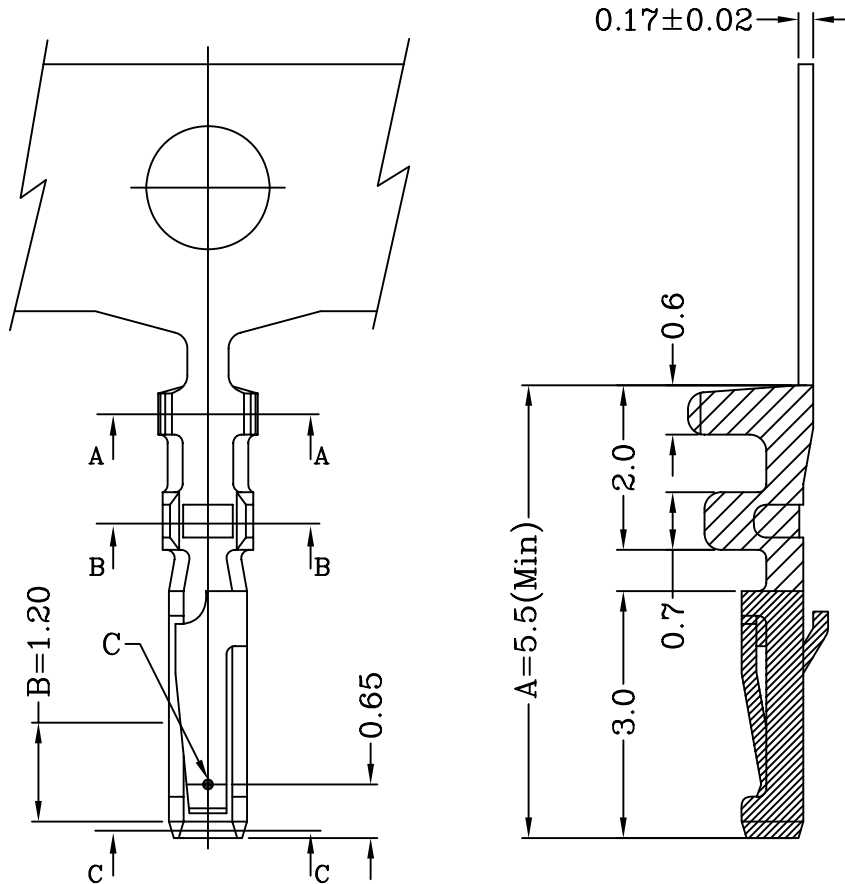

SECTION A-A

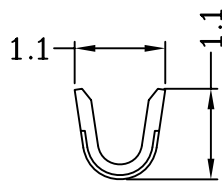

SECTION B-B

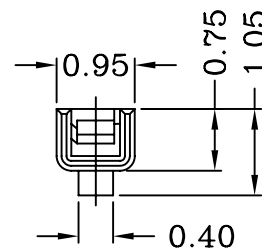

SECTION C-C

Specification & Ordering Information:

Part No	Wire Range	Insulation O.D.	Material	Finish	Qty/reel
A1254TOP-0*	AWG #28~#30	0.90mm(max)	Phosphor bronze	Gold over Nickel	20,000 pcs

REV.	ECN NO.	UNIT	TOLERANCE	PROJECTION	DRAWING	CHECK	APPROVAL
△	NEW DRAWING	mm	*** ±0.08		王昊	——	余望明
			** ±0.15				
			* ±0.25				