

深圳市占開科技有限公司

ShenZhen ZhanKai Technology CO.,LTD

TEL:0769-81802125 FAX:0769-81802126

DOCUMENT NO.

RDE0025A

SERIAL NO.

A1002H00-NP

Material: PBT UL 94V-0 (White)

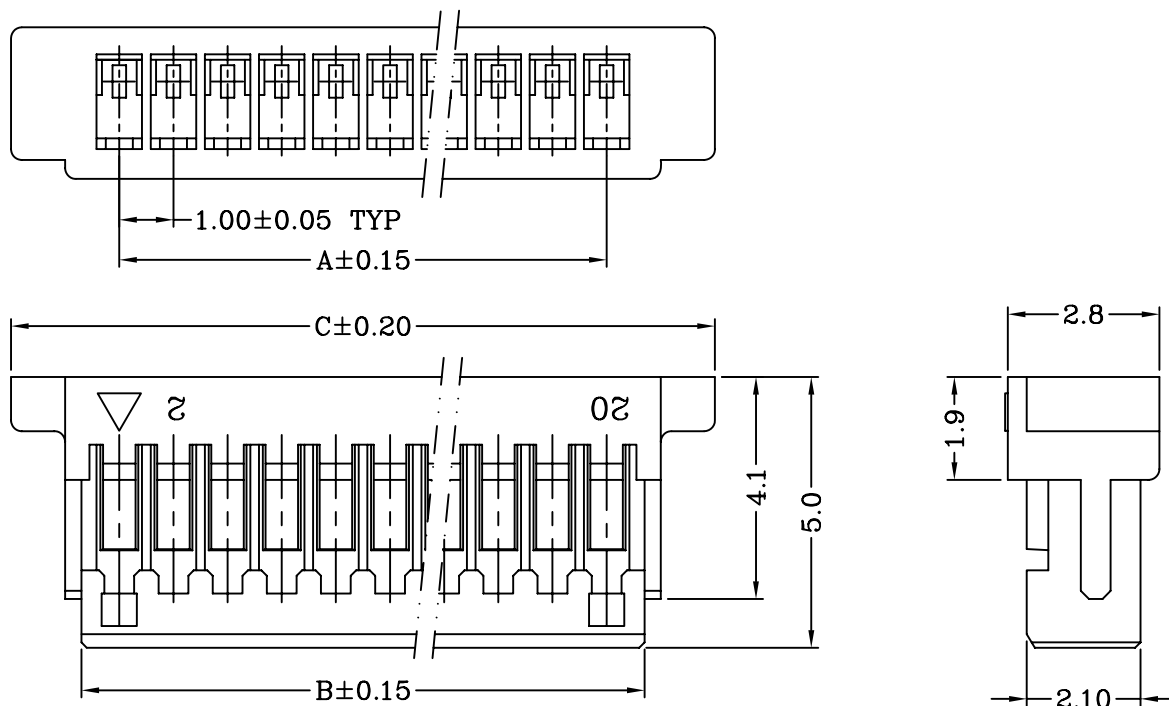

Dimensional & Ordering Information:

Circuits	Part No.	Dimensions			Pcs/Bag
		A	B	C	
2	A1002H00-2P	1.00	2.40	5.00	1000
3	A1002H00-3P	2.00	3.40	6.00	1000
4	A1002H00-4P	3.00	4.40	7.00	1000
5	A1002H00-5P	4.00	5.40	8.00	1000
6	A1002H00-6P	5.00	6.40	9.00	1000
7	A1002H00-7P	6.00	7.40	10.00	1000
8	A1002H00-8P	7.00	8.40	11.00	1000
9	A1002H00-9P	8.00	9.40	12.00	1000
10	A1002H00-10P	9.00	10.40	13.00	1000
11	A1002H00-11P	10.00	11.40	14.00	1000
12	A1002H00-12P	11.00	12.40	15.00	1000
13	A1002H00-13P	12.00	13.40	16.00	1000
14	A1002H00-14P	13.00	14.40	17.00	1000
15	A1002H00-15P	14.00	15.40	18.00	1000
20	A1002H00-20P	19.00	20.40	23.00	1000

REV.	ECN NO.	UNIT	TOLERANCE	PROJECTION	DRAWING	CHECK	APPROVAL
A	NEW DRAWING	mm	*** ±0.08		王昊	—	邹朝辉
B			** ±0.15				
			* ±0.25				

深圳市占開科技有限公司

ShenZhen ZhanKai Technology CO.,LTD

TEL:0769-81802125 FAX:0769-81802126

DOCUMENT NO.

RDE0027A

SERIAL NO.

A1002T

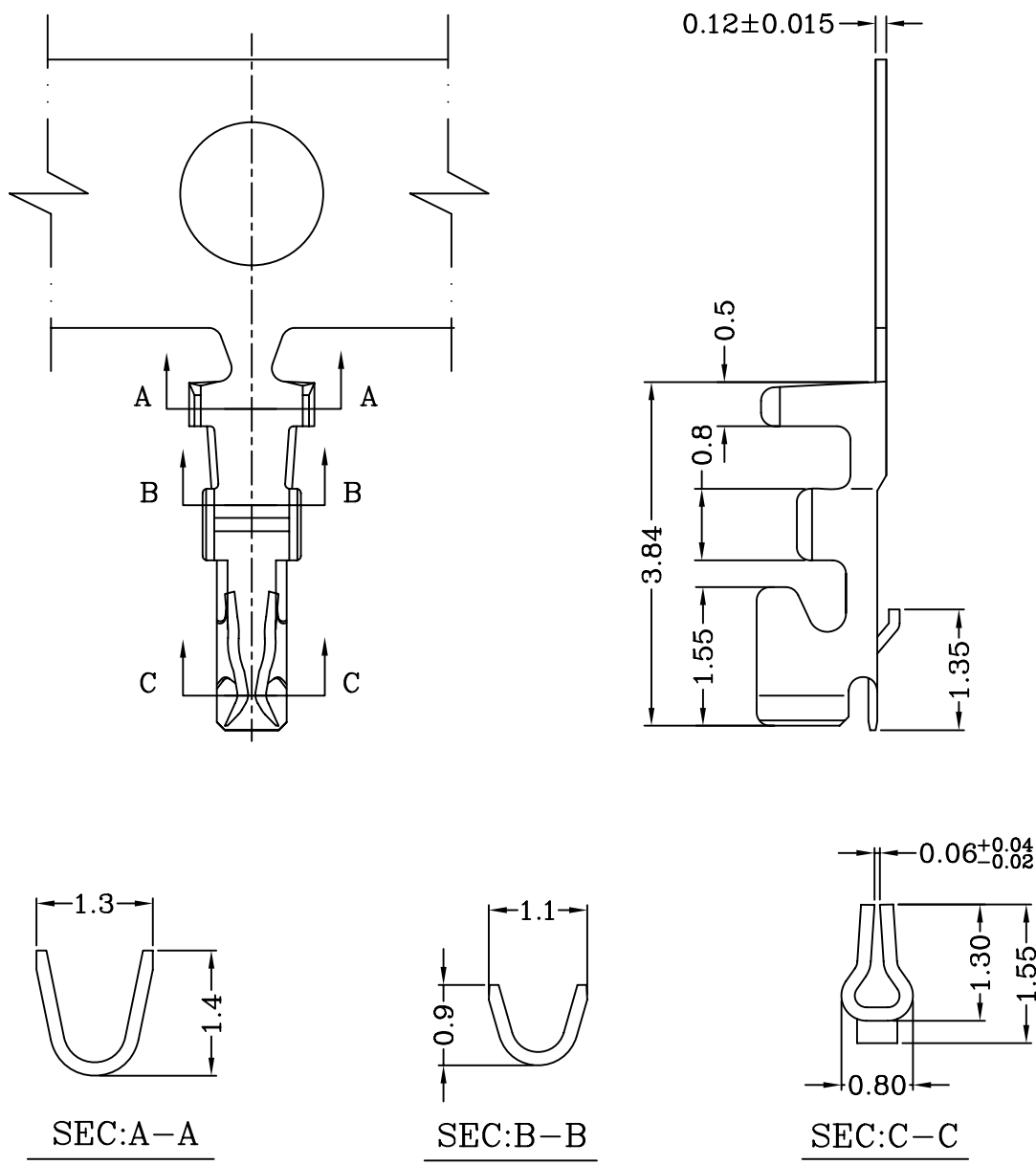

Specification & Ordering Information:

Part No	Wire Range	Insulation O.D.	Material	Finish	Qty/reel
A1002TOP-2	AWG #28~#32	0.80mm(max)	Phosphor bronze	Tin-plated	20,000 pcs

REV.	ECN NO.	UNIT	TOLERANCE	PROJECTION	DRAWING	CHECK	APPROVAL
A	NEW DRAWING	mm	*** ± 0.08		王昊	—	邹朝辉
B			** ± 0.15				
			* ± 0.25				