

深圳市占開科技有限公司

ShenZhen ZhanKai Technology CO.,LTD

TEL:0769-81802125

FAX:0769-81802126

DOCUMENT NO.

RDE0043A

SERIAL NO.

A1001HS0-30P-HL

Material:*Insulator:Nylon 46 UL 94V-0

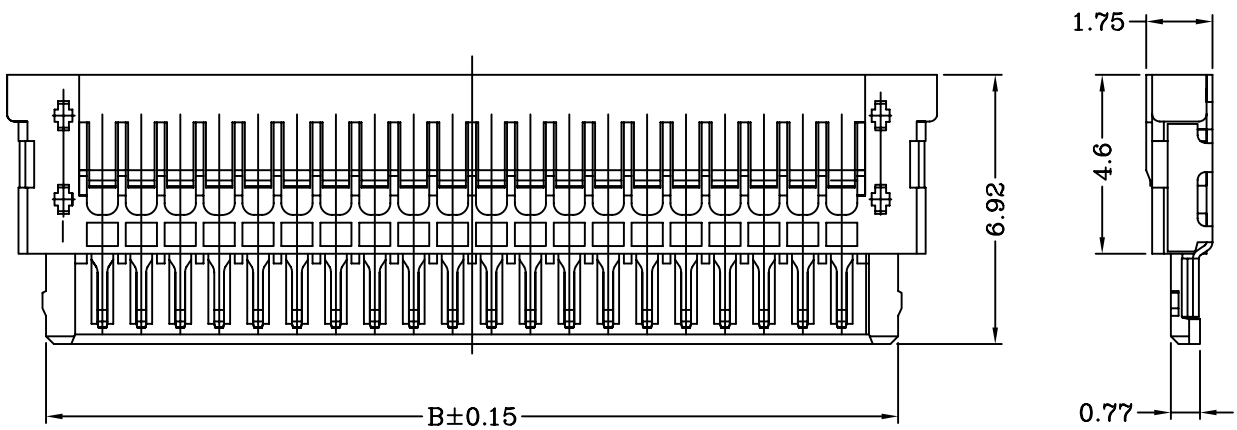
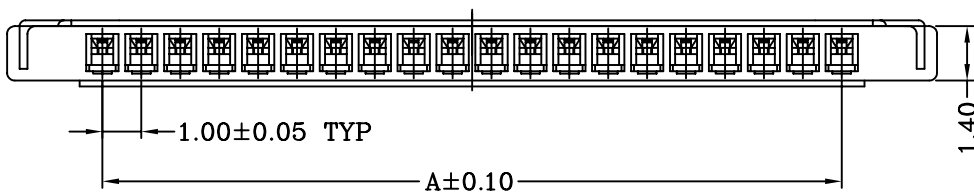
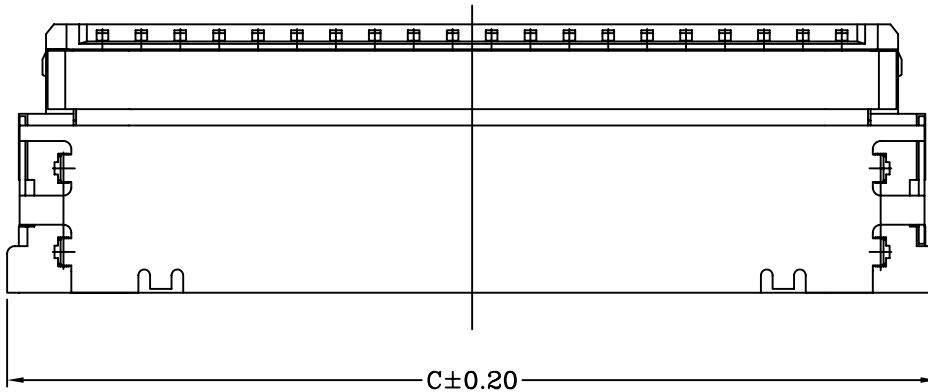

Dimensional & Ordering Information:

Circuits	Part No.	Dimensions			Pcs/Bag
		A	B	C	
30	A1001HS0-30P	29.00	31.90	33.50	500

REV.	ECN NO.	UNIT	TOLERANCE	PROJECTION	DRAWING	CHECK	APPROVAL
△	NEW DRAWING	mm	*** ±0.08		王昊	——	余望明
			** ±0.15				
△	N2005076		* ±0.25				

深圳市占開科技有限公司

ShenZhen ZhanKai Technology CO.,LTD

TEL:0769-81802125

FAX:0769-81802126

DOCUMENT NO.

RDE0043A

SERIAL NO.

A1001TOP-0*

A--Gold Plated Area

B--Tested Inside For Coating Thickness.

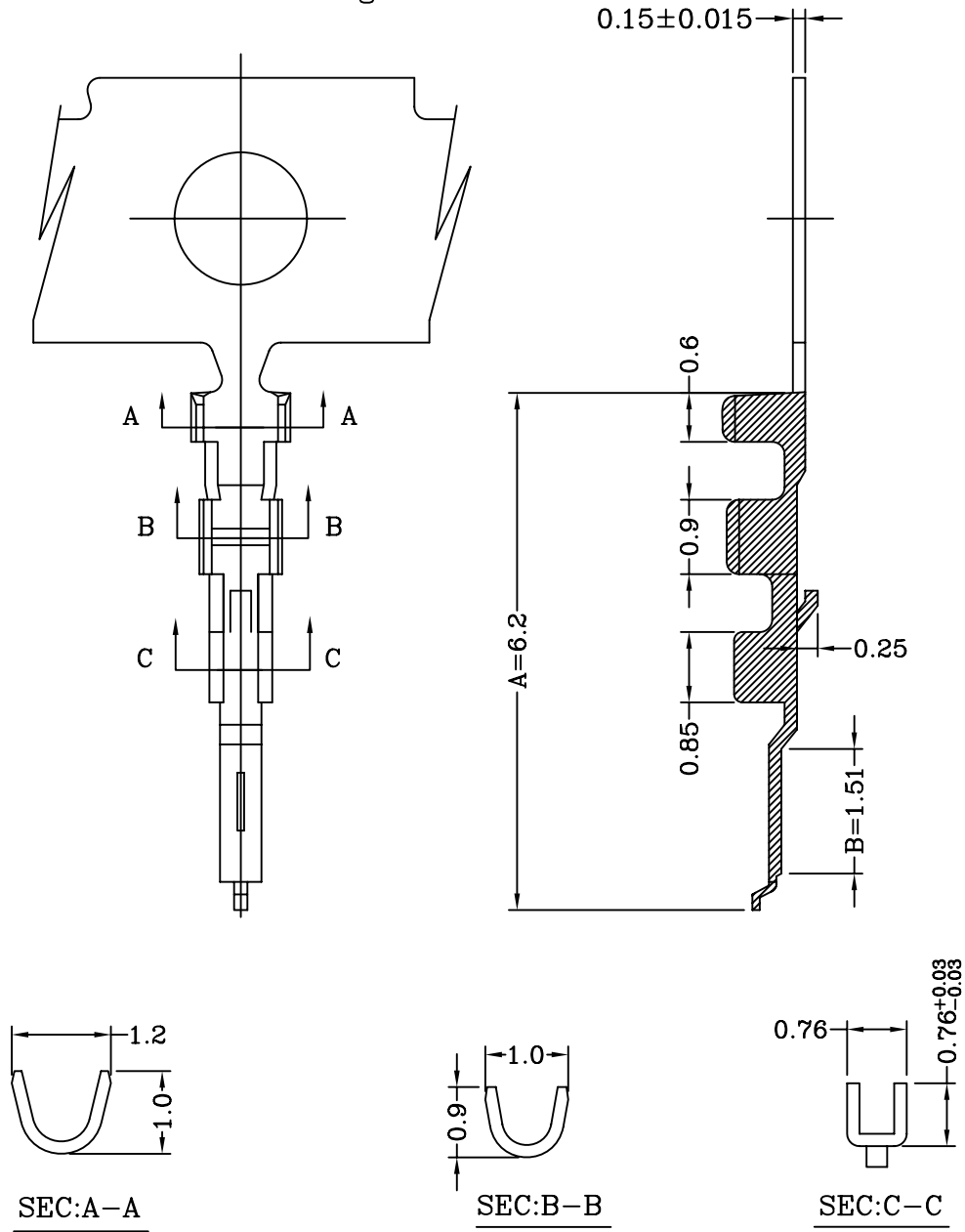

Specification & Ordering Information:

Part No	Wire Range	Insulation O.D.	Material	Finish	Qty/reel
A1001TOP-0*	AWG #30~#36	0.75mm(max)	Phosphor bronze	Gold over Nickel	20,000 pcs

REV.	ECN NO.	UNIT	TOLERANCE	PROJECTION	DRAWING	CHECK	APPROVAL
B	N2005009	mm	*** ±0.08		王 昊	—	余望明
C	N2007017		** ±0.15				
			* ±0.25				